

Three-phase asynchronous motors
Type of protection 'Flameproof Enclosure'
up to 10,000 kW



Three-phase asynchronous motors 'Flameproof Enclosure'

- with ribbed frame, up to 500 kW
- with integral air/air tube-type heat exchanger, up to 10,000 kW

... tested and certified to EG Ex Guideline 94/9/EG (ATEX 100 a)

Schorch explosion-protected motors are mainly used in the chemical or petrochemical industry. Motors to type of protection 'Flameproof Enclosure', 'Increased Safety', and 'Pressurized Apparatus' are used for Zone 1 installations, 'Non-sparking' for Zone 2.

Exd motors are designed in such a way that parts which can ignite an explosive atmosphere are placed in an enclosure which can withstand the pressure developed in an internal explosion, and which prevents the transmission of the explosion to the explosive atmosphere around the motor.

Design and construction are the results of decades of close co-operation with users, consultants, national certification bodies, and leading manufactures of driving and driven machines. It is thus a well-proven design, subject to continuous development and improvement, tried and tested in a vast number of applications worldwide under the most difficult operating and site conditions.

If there is a drive problem, consult us.



Pump drives in a pipeline booster station, Exd(e) IIB T4, 1,450 kW, 6 kV, 2pole

1/1234



Drives for crude oil pumps, Exd(e) IIB T4, 1,500 kW, 10 kV, 4pole

1/1235

Design

- To relevant standards IEC, VDE, DIN, ISO, EN
- Degree of protection IP55, possible up to IP65, Cooling methods IC411 (rib-cooled) and IC 511 (tube-cooled)
- Type of protection Exd(e) IIA, B or C T4 to EN 60079-1
- Terminal boxes also available to degree of protection Exd IIC
- Rated voltages from 2 kV to 11 kV
- Rated frequency 50 Hz or 60 Hz
- Converter-fed or connected to the system
- Number of poles 2p=2 to 20 (others on request)
- Construction IM B3 and IM V1 (others on request)
- Design can be modified to meet customer's specification
- Motors can be designed for voltages < 1,000 V or for converter-fed operation

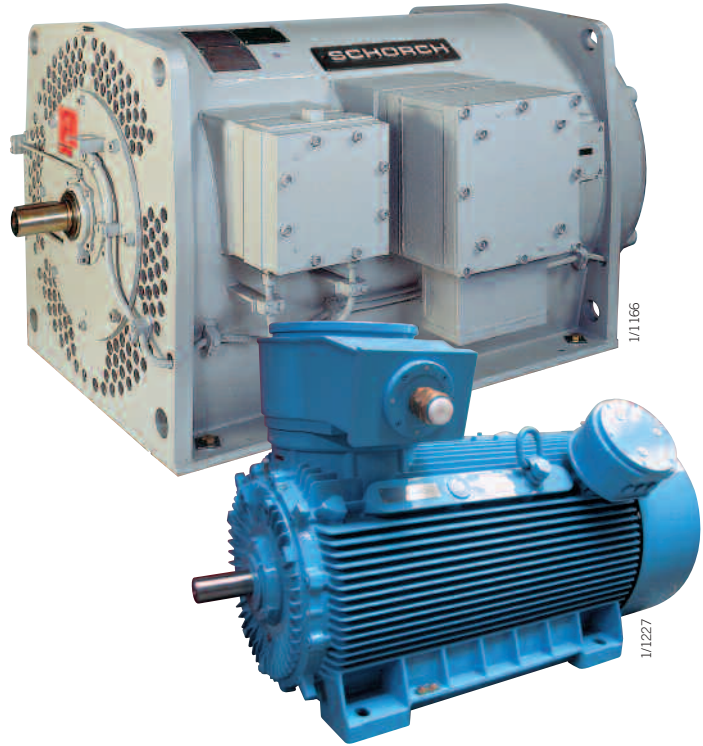

New marking since July 01, 2003

As a result of the certification procedure in accordance with the EG Ex Guideline 94/9/EG/ATEX 100 a and the ensuing CE marking, the following marking will have to be used for electrical apparatus:

- CE CE marking
- 123 Identification number of the notified body
- Ex Marking for explosion protection
- II Equipment group
- 2 Category (Zone 0, 1, 2)
- G Explosive atmosphere (G, D)
- Ex Explosion protection
- d Type of protection (p, d, e)
- IIB Explosion Group (A, B, C)
- T3 Thermal Class (T1 to T6)

All our motors are certified accordingly.

Rated outputs at 6 kV 50 Hz

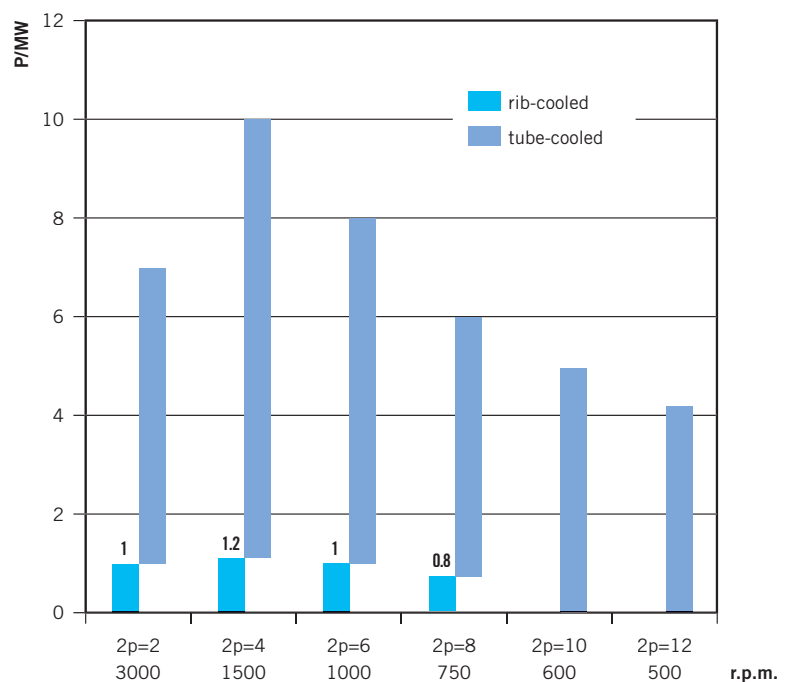

Frame and Corrosion protection

Frame

Rib-cooled design: Frame and endshields are made of spheroidal cast iron (EN-GJS-400-15). By means of the segmental arrangement of the cooling ribs and the asymmetrical position of the terminal box the cooling surface of the frame is enlarged as far as this is possible.

Tube-cooled design: The frame is a compact and rigid fabricated construction. It consists basically of two face plates connected by strong axial bars. These bars are braced against each other and are connected to the frame mantle. With horizontal machines, further rigidity is provided by the motor feet. The stainless-steel cooling tubes are expanded into the face plates.

Both frame designs are torsionally rigid and vibration-resistant. They are mechanically strengthened in accordance with the relevant rules for explosion-protected machines.

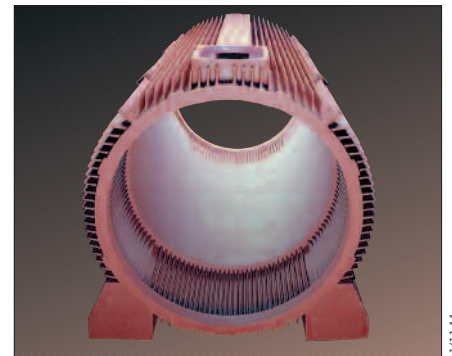

1/1144

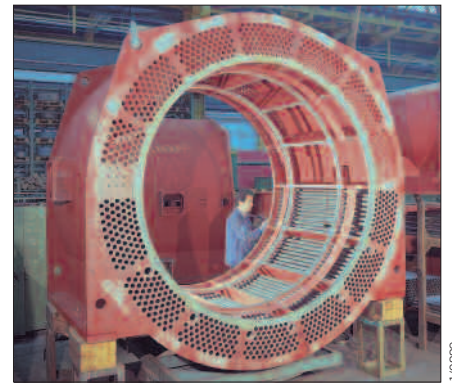

1/0889

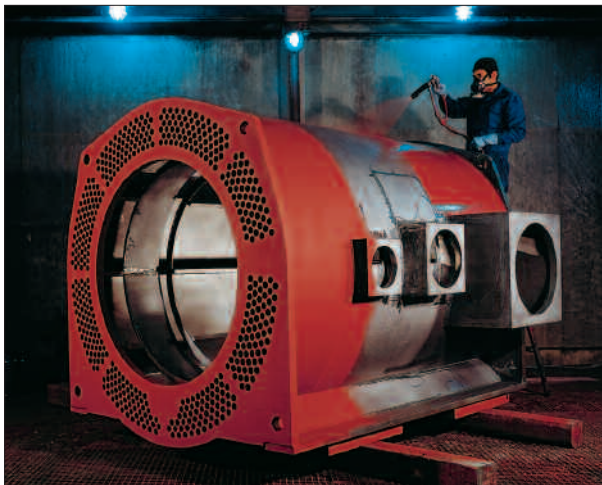

1/0612



Corrosion protection

Schorch paint systems are well tried and tested. They do not contain any lead, heavy metals or silicone.

Where operating and site conditions are stated in the order, we can provide a corrosion protection which we can guarantee for two years.

Prior to painting - either by flooding or spraying - all surfaces are thoroughly sand-blasted.

With basic-design machines, the paint system consists of a coat of primer, an intermediate and a finishing coat; standard shade is RAL 7031.

This paint system is suitable for both indoor and outdoor installation, including industrial and sea atmospheres. It is resistant to light, and to temperatures from - 40° C to + 120° C. It is non-porous, elastic, and resistant to shock and wear.

For specific operating and site conditions, special paint systems are available.

Anti-friction bearings

The type of bearings to be used is determined by the explosion group, the construction, the speed, the output and any additional loads of the motor. Depending on these parameters or the customer's specification, anti-friction or sleeve bearings are provided.

For particularly high radial loads, motors can be provided with an additional cylindrical roller bearing at the D-end. Shaft seals are maintenance-free and provide protection against the ingress of dirt and spray water in accordance with degree of protection IP55.

Lubricators and grease slingers ensure constant proper lubrication of the bearings. Outer bearing covers are provided with a sufficiently large space for spent grease and, where required, a grease drain.

Rib-cooled design

Series 3 anti-friction bearings. Basic-design IM B3 motors are fitted at the D-end with a grooved ball bearing (locating) and at the N-end with a cylindrical roller bearing (non-locating).

On the motor side of the bearing, a gap seal is provided, and on the outside a labyrinth ring.



Anti-friction bearing with lubricator

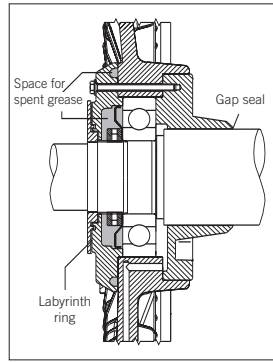

Anti-friction bearing arrangement

Tube-cooled design

Series 2 or 3 anti-friction bearings. Basic-design IM B3 motors are fitted at the D-end with a grooved ball bearing (locating) and with cylindrical roller bearing at the N-end (non-locating).

As shaft seals, a labyrinth is provided at the motor side of the bearing and a V-ring on the outside.



Anti-friction bearing with lubricator and grease drain

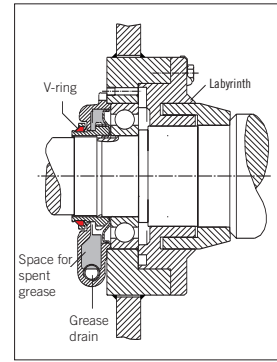

Anti-friction bearing arrangement

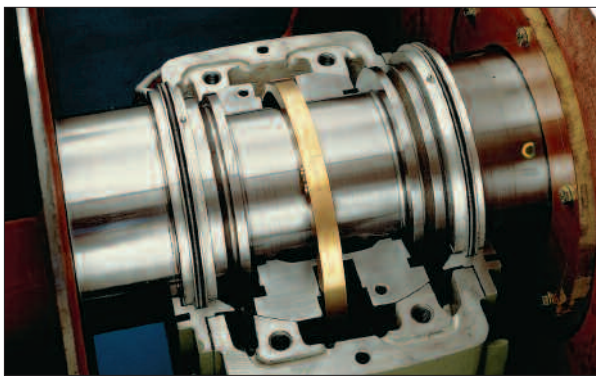

Sleeve bearing with ring oiler

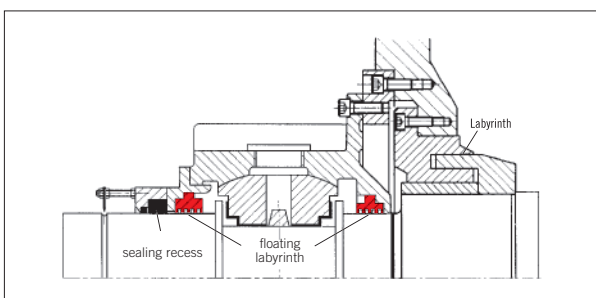

Shaft seals for sleeve bearings

Sleeve bearings

On request, tube-cooled motors can be fitted with sleeve bearings. These are of the split, flanged type.

Depending on the bearing load in service, bearings with loose ring oilers (self lubrication) or with force-feed lubrication are used. Subsequent conversion from self to force-feed lubrication is possible.

Sleeve bearings are non-locating. Shaft end float is max. ± 3 mm. On request, a locating bearing can be provided at the D-end. On the motor side of the bearing, sealing is provided by a floating labyrinth seal and a stationary labyrinth. On the bearing outside, a floating labyrinth seal and an additional sealing ring are used.

Shaft seals are maintenance-free. They provide reliable protection against the ingress of dust and spray water in accordance with degree of protection IP55.

Ventilation system

Rib-cooled design: The ventilation system is characterized by the shape of the fan, the fan cowl and the arrangement of the cooling ribs.

The uni-directional external fan is arranged at the N-end.

To ensure a forced internal air circulation, vans are provided on the short-circuiting rings.

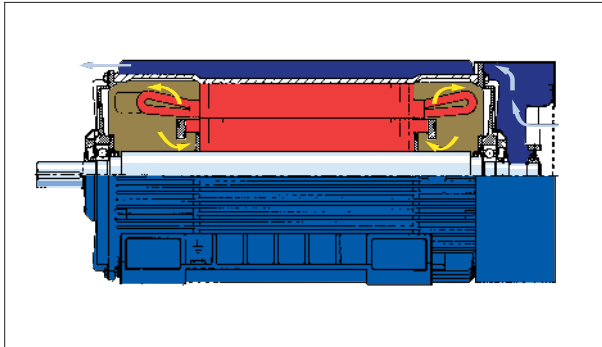

Tube-cooled design: Tubes, concentrically arranged around the active part, act as air/air heat exchangers.

The internal air flow through axial air ducts in the shaft and radial air ducts in the active part ensures a near uniform temperature distribution in the motor.

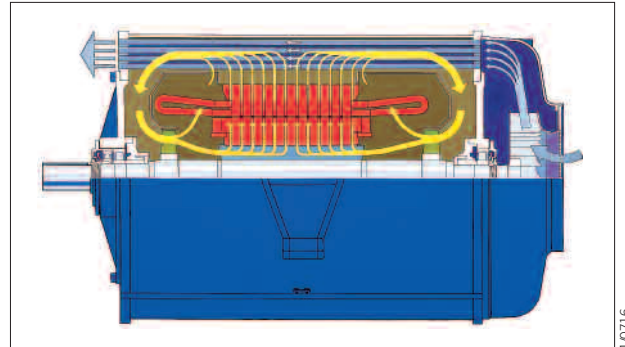

Noise

In view of ever more stringent regulations concerning protection of the environment and safety at work, keeping the noise generated by electrical machines as low as possible is of particular importance.

From the outset, i.e. including the basic design, our machines are designed as low-noise machines. This is achieved by an interactive design of all important system components:

- Frame
- Ventilation system
- Electro-magnetic design
- Bearings

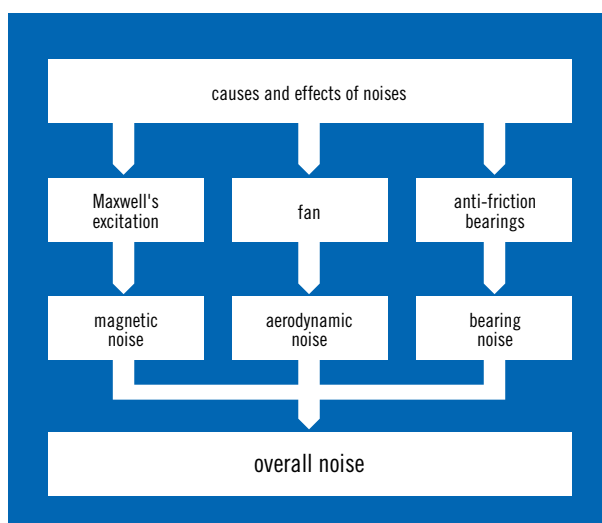

Sources of noise in electrical machines

Noise reduction

Where extreme noise requirements are to be met, various tailor-made solutions are available.

Rib-cooled machines are provided with an acoustically treated frame mantle.

With tube-cooled machines, depending on the number of poles and the overall machine design, acoustically treated absorbers for air inlet and outlet and/or an acoustically treated frame mantle are used. Combined, these measures can offer noise reductions of up to 12 dB.



Acoustically treated fan cover

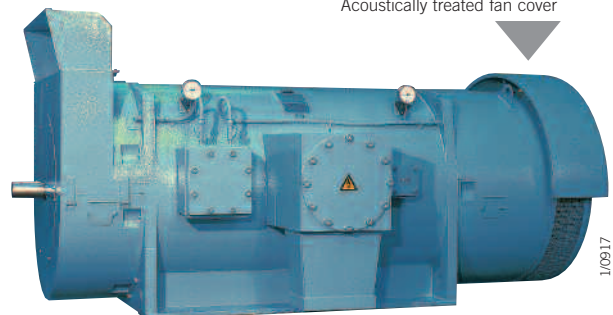

Motor with air outlet absorber and acoustically treated frame mantle

Developments in the field of insulation led in the 80's to the introduction of the V-Celastik® insulating system. This is a system using the VPI technique which corresponds to Class F.

VPI means that the complete stator (core and windings) is impregnated with artificial resin in a vacuum/pressure process. The result is a winding with excellent thermal, electrical and mechanical properties.

The constantly high quality of the high-voltage insulation is ensured by the latest in manufacturing equipment.

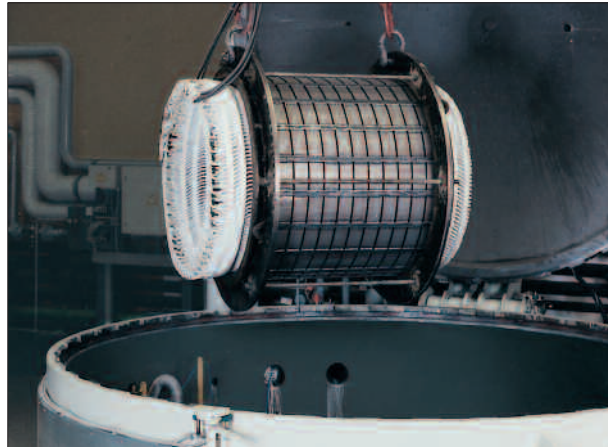

Wound stator prior to impregnation

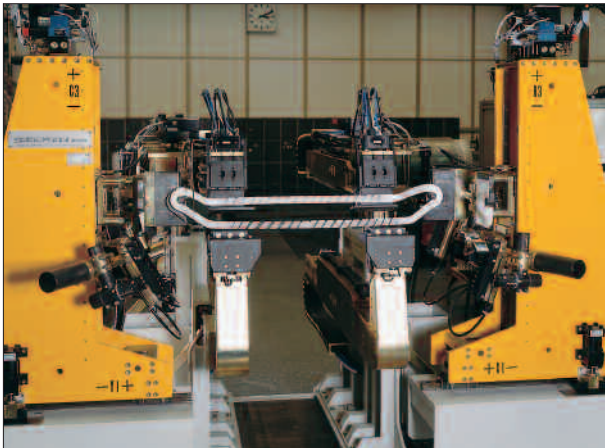

Coil-spreading machine

Impulse withstand capability

The impulse withstand level of the windings is well above the specified minimum of $4 xU_N + 5 \text{ kV}$ so that additional protective measures against overvoltages have to be taken only in exceptional cases.

Mechanical stability

Windings are designed to meet all mechanical stresses occurring in service. The bracing of each winding is calculated, using a special computer program developed at Hanover University.

This calculation is based on the highest stresses to be expected, e. g. reconnection against 100 % residual voltage in phase opposition.

Quality assurance

The manufacture of windings is, as is the entire company, subject to a certified QA system to DIN EN ISO 9001.

Materials, manufacturing techniques and processes are continually monitored and the results recorded. Additional tests on winding elements, or complete windings, can be carried out on request.

® Registered Trademark



Coil-taping machine

Squirrel-cage rotor - rugged and low-loss

In the basic design, the deep-bar squirrel-cage winding consists of copper bars brazed to the short-circuiting rings. Depending on expected rotor stresses, either butt or grooved bar-to-ring joints are used.

The comparatively low resistance of the copper winding leads to low current/heat losses and, consequently, to high efficiencies.

The copper bars are driven into the rotor slots and peened to ensure absolutely positive seating. This prevents any movement of the cage winding relative to the rotor core, and makes for optimum heat transfer, essential for long acceleration or locked-rotor times.

For higher starting torques, or to meet the requirements of particular torque characteristics, special slot designs are used.

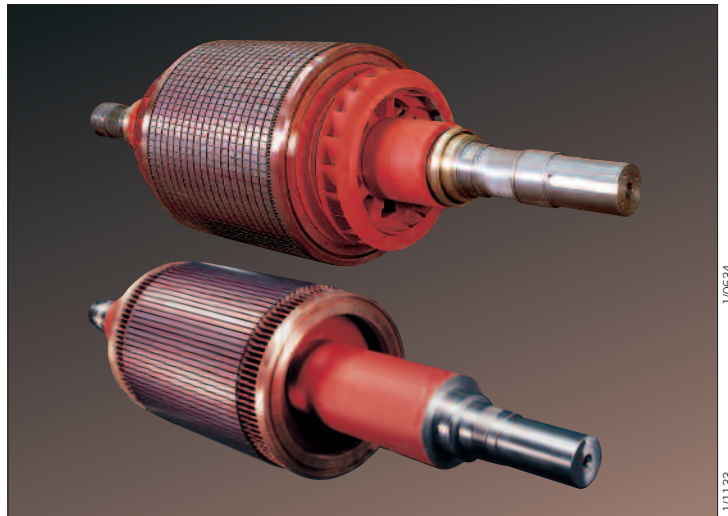

Rotor with copper cage winding

1/0634

1/1133

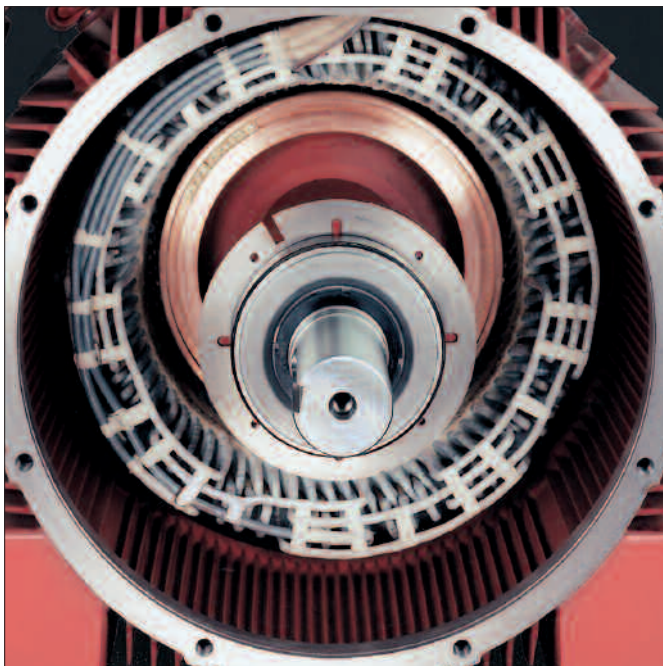

Connecting side of endwinding

1/1134

Stator winding

The stator winding is a corded two-layer winding. It is connected in star, with the neutral being connected at the winding overhang. The three winding outlets are brought out to the terminal box via flameproof cable glands. On request, all winding ends can be brought out. In that case, the neutral is formed in a separate terminal box.

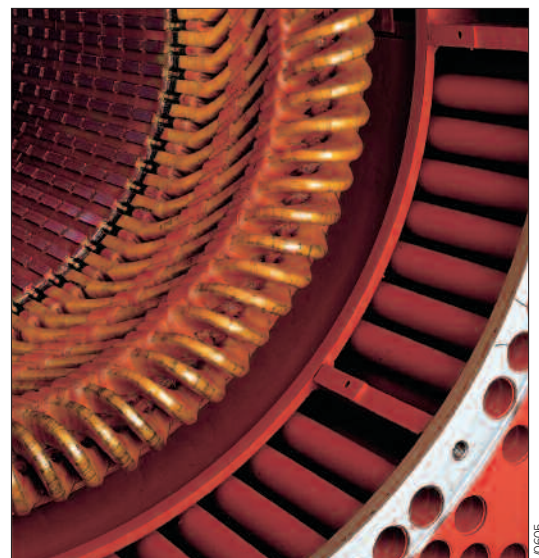

Endwinding

1/0605

Operator safety

Our terminal boxes combine high short-circuit strength (terminals) with reliable shatterproofness (terminal box).

In the event of a fault, the internal pressure is vented in one direction only, thus preventing injuries due to flying debris. These properties have been verified in a neutral test laboratory in numerous internal fault tests on an infinite bus.

Terminal boxes, Type of protection 'Increased safety' Exe (Standard)

Ample dimensions of the terminal boxes make for simple and safe connection of the supply cables. For the connection, either cable lugs (standard) or terminal clamps (special) are provided. Compound filled cable entries are available, on request.

Terminal boxes meet the requirements of degree of protection IP55 to IEC 60529, and are designed for outdoor installation.

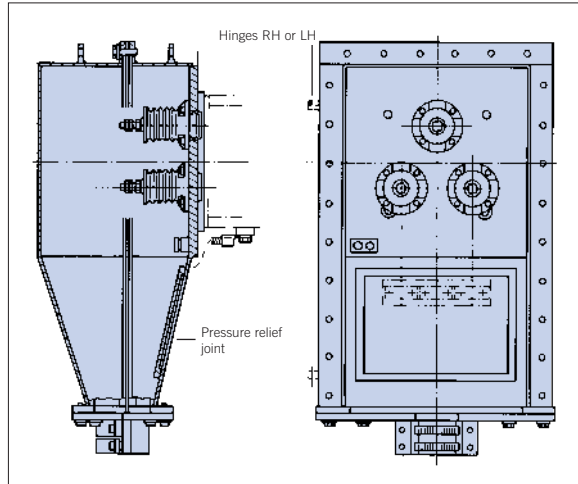

Terminal box for 10 kV and for fault levels 330 or 800 MVA. Relief joint at the rear.

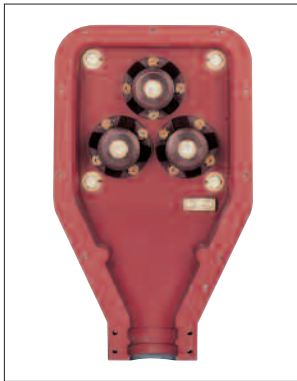

Standard terminal box with 6 kV cast-resin bushings



Standard 10 kV terminal box

Minimum conductor cross-sections

In order to ensure the realisation of our safety concept, the following min. conductor cross-sections must be observed:

System fault level	Min. cond. cross-section	
	Cu in mm ² at U _N =	
MVA	6kV	10kV
<200	70	70
>200-250	95	70
>250-350	150	95
>350-500	185	150
>500-800	-	185

Terminal boxes, Type of protection 'Flameproof enclosure' Exd IIC (Special design)



Main and auxiliary terminal boxes Exd IIC

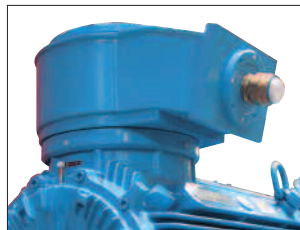

On request, Exd terminal boxes can be provided.

They are of fabricated construction and consist of a bushing plate, the box with cover, and an entry plate.

Entries can be either cable entries to EN 60079-1 or conduit entries.

These terminal boxes are separately tested and certified.

Monitoring, Design variants

Monitoring devices

On basic-design machines, holes are provided in the bearing housings for the installation of vibration sensors, on request.

Where the motor is covered by an overall monitoring system, sensors/monitoring devices can be provided for the continuous monitoring/indication of electrical, thermal or mechanical data.

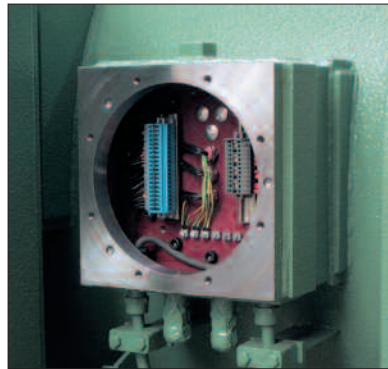

1/0101

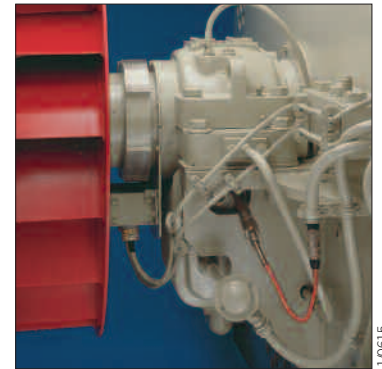

1/0615

Design variants



1/0683

HP compressor drive, Exd IIA T3, 10,000 kW, 11 kV, 4-pole.
Low-noise design with absorber and air outlet silencers.

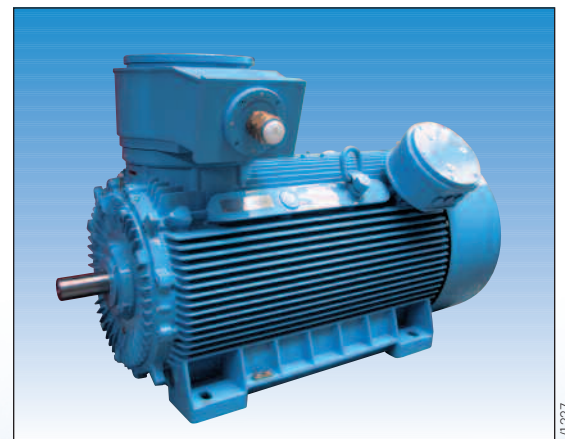

1/1227

Drive for screw-type compressor, Exd IIC T4, 315 kW, 6 kV, 2-pole

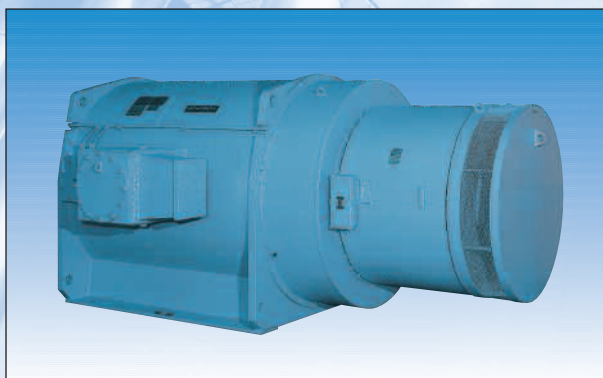

1/0514

Converter-fed drive for screw-type kneader, Exd IIC T4, 1,500 kW, 900 V,
600 - 1,600 rpm; independent cooling



1/0208

Drive for pipeline oil pump, Exd(e) IIA T3, 2, 600 kW, 6 kV, 2-pole;
bearings with force-feed lubrication

Modern test facilities

European standards contain detailed test procedures for the verification of type of protection 'Flameproof Enclosure'. These tests serve to prove that the motor can withstand an internal explosion and that the transmission of an explosion to the surrounding atmosphere is prevented by means of adequate gaps at the shaft and the centring spigots of the motor endshields.

For these tests, the motor is filled with a gas-air mixture, prescribed for the respective explosion group. This mixture is ignited by an electric spark. Explosion pressures are measured, recorded and evaluated by a piezo quartz, an amplifier and a digital scope. The gas-air mixture to be used in the test is prepared in a pumpless plant. The mixing ratio is regulated and monitored by an oxygen analyser.

We are the only European motor manufacturer with such modern testing equipment.

Tests are witnessed by a representative of an official testing body. Test procedure and test results are recorded in a Test Report.

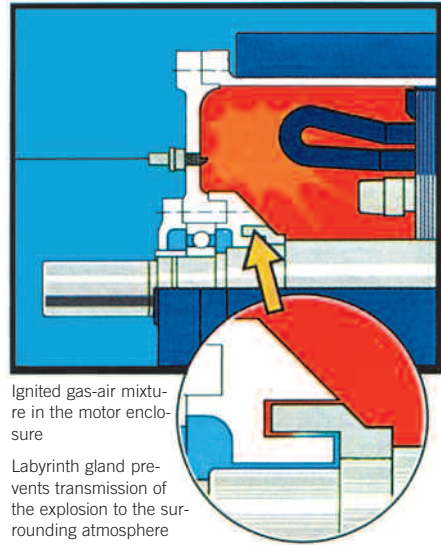

Explosion test laboratory

Explosion test in a pressure vessel for test specimens up to 1.6 m diameter (\leq Type 60..)

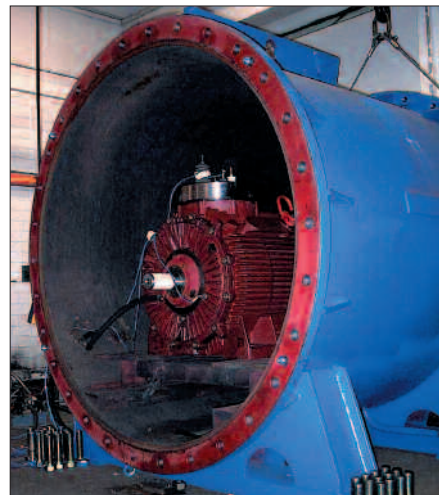
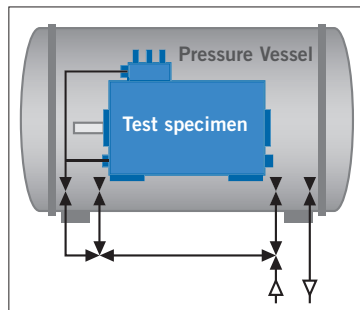

Equipment for mixing and monitoring the gas-air mixture

Explosion test in a polythene shroud for test specimens of more than 1.6 m diameter ($>$ Type 60..)

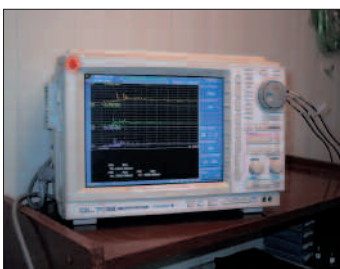
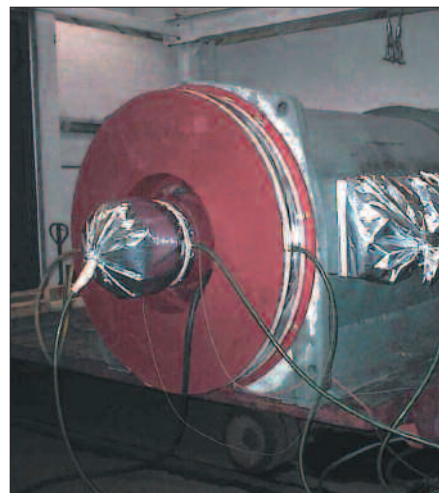
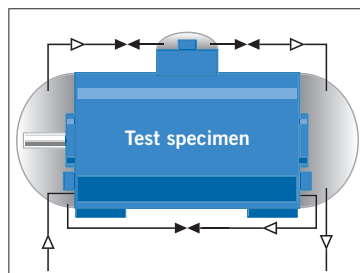

Evaluation of transient explosion pressures



SCHORCH

ATB Schorch GmbH
Breite Straße 131 · 41238 Mönchengladbach
Germany
Phone +49 2166 925-0
Fax +49 2166 925-100
mail@schorch.de
www.schorch.de